

# Wearable ECG Platform for Continuous Cardiac Monitoring

Preejith SP, Dhinesh R, Jayaraj Joseph, Mohanasankar Sivaprakasam

**Abstract**— An ultra-low power ECG platform for continuous and minimally intrusive monitoring for systems with minimal processing capabilities, is presented in this paper. The platform is capable of detecting abnormalities in the ECG signal by extracting and analyzing features related to various cardiac trends. The platform is built to continuously operate on any of the 12 leads and the presented work includes a single lead implementation that works on lead I or II. A single lead, wearable ECG patch that can detect rhythm based arrhythmias and continuously monitor beat-to-beat heart rate and respiratory rate has been developed. In addition, the device stores raw ECG waveform locally and is designed to run for 10 days on a single charge. The ECG patch works in conjunction with a front end device or tablet and updates the results on the tablet interface. Upon detection of an abnormality or an arrhythmia the device switches to an ECG visualization mode enabling manual analysis on the acquired signal. The front end device also functions as a gateway for remote monitoring. The functionality and processing capabilities of the platform along with the validation tests carried out in a controlled setting are presented.

## I. INTRODUCTION

The electrocardiogram (ECG) is a composite signal representing the electrical activity of the heart and is one of the most useful diagnostic tools in emergency medicine. A conventional 12 lead ECG system consists of 10 electrodes which are placed on the limbs and chest of the patient. The 12 leads give a measure of electrical activity from 12 different angles, which are essential for the identification of various cardiac arrhythmias [1], [2].

Patients who have cardiac problems or discomforts are fitted with a Holter monitor for 24-48 hours [3]. Holter stores the data continuously which is later analyzed to diagnose the problem. Although these devices are used extensively, they have many shortcomings. Holter monitoring requires electrodes to be attached to the patient's chest via long wires, which adds to noise and discomfort. Absence of intelligent algorithms for detection and analysis of arrhythmia which can run on low power systems limit the use of Holters to offline applications [4].

Preejith S P is with Healthcare Technology Innovation Centre-IITMadras, IIT Madras Research Park, India (phone: +91 044 66469830; preejith@htic.iitm.ac.in).

Dhinesh R is with Healthcare Technology Innovation Centre-IITMadras, IIT Madras Research Park, India (rdkrish02@gmail.com).

Dr.Jayaraj Joseph is with Healthcare Technology Innovation Centre-IITMadras, IIT Madras Research Park, India ( jayaraj@htic.iitm.ac.in).

Dr.Mohanasankar Sivaprakasam is with Department of Electrical Engineering, Indian Institute of Technology Madras, India and Healthcare Technology Innovation Centre-IITMadras, IIT Madras Research Park, India (mohan@ee.iitm.ac.in).

Despite the standard 12 lead Holter being an established means for diagnosis of cardiac problems, a single lead ECG could come in handy to indicate discernible abnormalities relating to the onset of severities [4]. In addition to heart rate and heart rate variability monitoring, these systems can be used for measurement of respiratory rate and detection of rhythm based arrhythmias [5]. Such devices can be used as event monitors for continuous long term monitoring to detect cardiac trends and probably detect initial markers at the onset of cardiac irregularity [5].

Wireless ECG patches which monitors and stores the cardiac electrical activity or provide continuous real-time heart rate and heart rate variability are available in market today. These monitors either rely on transmitting the raw data to a base station or store the data in the local memory for future analysis [6]. These devices are not widely used for continuous monitoring in hospitals or remote monitoring applications because of their inability to provide clinically significant analysis and assistance in decision making.

A novel platform implementation of a wireless single lead ECG system in a wearable form factor for continuous monitoring is presented in this paper. The platform incorporates an elaborate cardiac rhythm feature extraction software suite that can be implemented on systems with power constraints and low processing capabilities. In addition to real-time analysis, the device comes with local storage and ECG visualization options to improve ease of access of ECG data for clinicians.

## II. SYSTEM DESIGN

The platform technology developed includes a wearable ECG patch with wireless connectivity and a gateway device for data visualization and cloud interface. The patch houses a feature extraction and rhythm analysis software suite designed for low power applications. Beat-to-beat heart rate, respiratory rate, heart rate variability and cardiac rhythm based arrhythmias are continuously monitored and updated on the gateway device. In addition, the device also stores the raw data locally for offline analysis. Fig. 1. shows a block diagram representation of the proposed platform.

The data obtained from a single lead ECG patch worn across the heart to probe lead I (in women) or lead II (in men) contains multiple characteristics such as heart rhythms, P wave, R-R interval, QRS complex, PR interval and breathing induced artifacts that can be extracted using feature extraction techniques. ECG features obtained from lead I / lead II are processed using sophisticated yet lightweight proprietary algorithms to detect the onset of rhythm based cardiac disorders. R-R interval is used in the

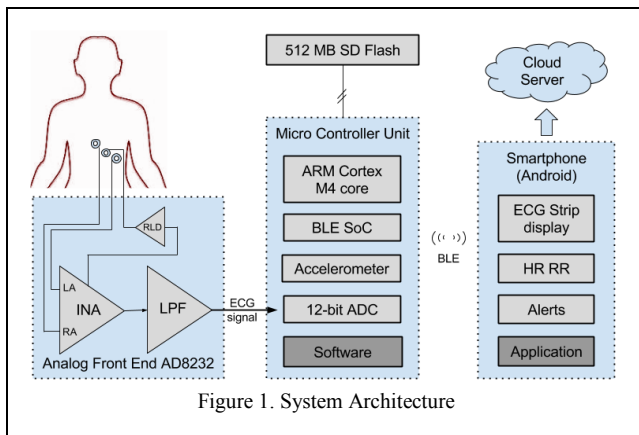

Figure 1. System Architecture

estimation of beat-to-beat heart rate. Breathing induced artifacts cause distortions in the acquired signal which on processing renders the respiratory pattern from which the respiratory rate is computed [7].

A right leg drive circuit is included which takes in the common mode voltage from the electrodes, amplifies it negatively and drives it back to the body. This reduces baseline wandering in the ECG waveform and eliminates 50Hz power line interference [8], [9]. Since majority of the use cases are ambulatory, proper lead contact is ensured all the time by a dedicated leads off detection module that alerts the caregiver and the user about leads being detached. The device also integrates a 3 axis accelerometer to detect body posture, activity and restoration of signals affected by motion artifacts. Both the raw ECG signal and accelerometer data containing activity information are stored on an external flash memory which can store 14 days of continuous data.

The device operates in two modes viz. continuous monitoring mode and real time visualization mode. By default, continuous monitoring mode is enabled where the signal acquired is processed using proprietary algorithms to estimate heart rate, respiratory rate and detect events that could be potential arrhythmias. Results are transferred to the front end application upon completion of algorithm execution, every 10 seconds. Real time visualization mode

TABLE I. DEVICE SPECIFICATIONS

Parameter	Specification	
	Analysis mode	Stream mode
Max. current consumption	3 mA (at 3.3V)	9 mA (at 3.3V)
Battery life cycle	14 days	4 days
ADC sampling rate	250 Sps	750 Sps
Max. communication range	10 m	
Weight (with enclosure)	31 g	
Dimensions (L x B x H)	13 mm x 5 mm x 11 mm	
ECG signal resolution	12 bit	
Non – volatile memory	512 MB	

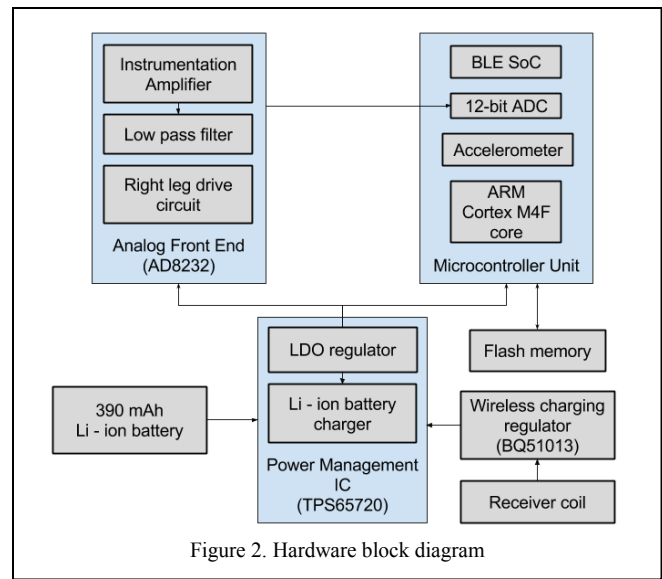

Figure 2. Hardware block diagram

has enhanced support for signal analysis and interpretation as it streams real-time data at a high sampling rate of 750 samples per second (Sps) to the front end application. Table I summarizes the electrical specifications of the device.

#### A. Hardware

The hardware block diagram of the proposed system is shown in Fig. 2. The main blocks in this low power system include ECG Analog Front End (AFE) with shutdown functionality to save power, a low power Microcontroller Unit (MCU) with an inbuilt Analog to Digital Converter (ADC) and Bluetooth Low Energy (BLE) module, power management IC, wireless charging components and a Li-ion battery. Hardware was designed with performance and low power consumption as the main design criteria.

AD8232 is a complete ECG measurement solution available on a single chip package. It consists of an instrumentation amplifier with a configurable gain, a low pass filter, digital circuitry for leads-off detection and a right leg drive circuit. Preprocessing operations such as filtering, band limiting and amplification are done by the AFE on the ECG signal which is then fed to the input of the ADC. ADC samples the analog ECG signal at 250 Sps or 750 Sps depending on the mode of operation. MCU stores the ECG

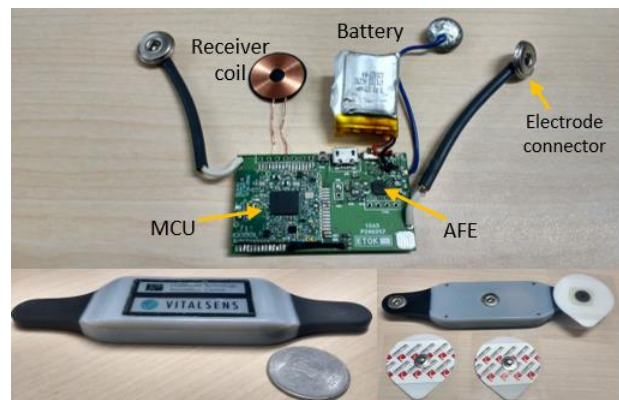

Figure 3. Hardware developed

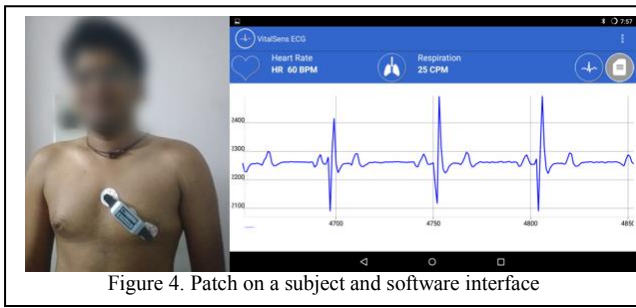

Figure 4. Patch on a subject and software interface

signal in the onboard memory, with time stamp and processes the signal. The results are transmitted to the front end device using the BLE module. The software application running in the front end device receives the data and handles the events related to indications and alerts. The device is powered by a 390 mAh battery and is enclosed in a sterilizable bio-compatible ABS enclosure. Disposable ECG electrodes are used with the device which will adhere the patch on to the chest. The hardware developed along with disposable electrodes is shown in Fig. 3.

### B. Software

The front end application connects with the ECG patch securely through BLE, sends control commands and receives results from the device. Indication of alerts is supported by the software application to warn the user of potential severities and leads-off events. To enable manual analysis of the patterns and rhythm, the software application supports real-time visualization of ECG signal. Real time streaming feature is automatically invoked from the device upon detection of potential arrhythmia thereby making it

TABLE II. ABNORMALITIES AND CORRESPONDING FEATURES

Abnormalities	Corresponding Features
Atrial Fibrillation	RR interval, P wave
Atrial Flutter	P wave
Asystole, Pause	QRS complex, P wave, T wave
Atrial abnormality	P wave
Wandering Pacemaker	P wave
Supra Ventricular Ectopic	QRS complex, P wave, PR interval
Junctional Escape	QRS complex, P wave
Sinus Arrest	RR interval
AV Blocks	RR interval, PR interval, QRS complex
Sinus Bradycardia	RR interval
Sinus Tachycardia	RR interval
Ventricular Tachycardia	RR interval, P wave, QRS complex
Ventricular Flutter	RR interval, P wave, QRS complex
Idioventricular Rhythm	RR interval, P wave, QRS complex
Premature Ventricular Contraction	QRS complex, P wave
Ventricular Escape	QRS complex, P wave

convenient for doctors to carry out timely intervention. The functionality of the device is extended to securely upload data to the hospital cloud service where doctors can stay updated on the condition of patients. Fig. 4. shows a subject wearing patch along with software interface.

### C. Algorithm

A novel approach is proposed where ECG samples are continuously acquired and processed in real-time. Every 10 seconds, the results are updated on the front end device connected to the ECG patch via BLE. This continuous acquisition and analysis modality ensures that all abnormalities in the ECG waveform are captured.

The sequence of operations carried out by the proposed algorithm is represented in Fig. 5. The signal is passed through an anti-aliasing filter with a cutoff frequency of 40 Hz to remove high frequency noise components. R-R interval is calculated from the adjacent R peaks from which beat-to-beat heart rate is computed. Beat-to-beat heart rate values are sent to the front end device on-demand or averaged out to give the average heart rate in beats per minute (bpm). The signal reconstruction section of the algorithm uses accelerometer data acquired at a low sampling rate of 25 Sps, to detect and remove motion artifacts.

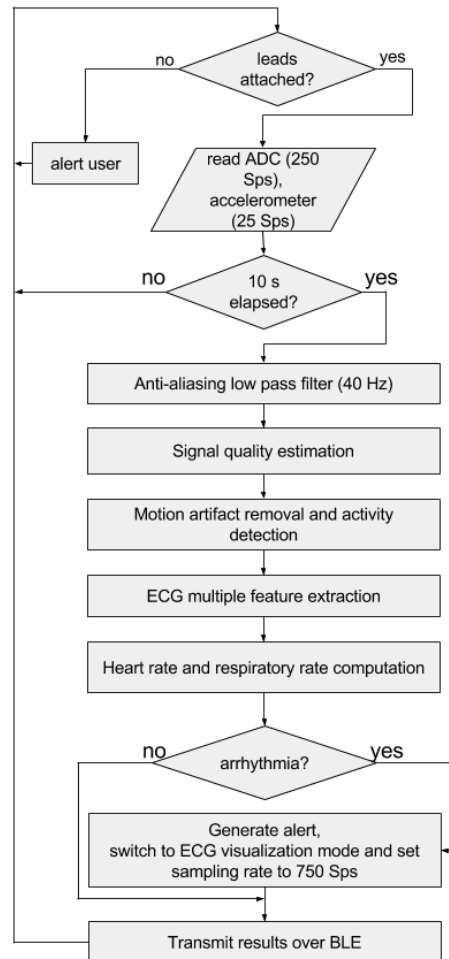

Figure 5. Algorithm flow chart



Figure 6. Test setup

Feature extraction algorithms are applied on the motion artifact removed signal to extract the features critical for detection of various arrhythmias. For example, common rhythm based arrhythmias such as tachycardia, where heart rate is abnormally high, bradycardia, where rhythms are too slow and fibrillations including ventricular fibrillation and atrial fibrillation, where rhythm becomes irregular and distorted, and can be detected by analyzing RR interval and P wave.

Table II lists different arrhythmias along with their features which can be detected by the patch. The proposed platform implements light weight algorithms that can be ported on low power ARM devices. Upon detection of an arrhythmia the system notifies the front end application to alert the caregiver/doctor.

### III. TESTS AND RESULTS

The accuracy of the patch in reliably detecting rhythm based arrhythmias and other abnormalities and then switching to ECG visualization mode for caregiver/doctor intimation was validated using simulated data. A test platform capable of generating various types of rhythm based arrhythmias and normal ECG with varying heart rates from 50 to 150 bpm was setup using a Fluke ProSim 8 ECG simulator. The single lead ECG patch developed was connected to RA and LA electrode points and the right leg drive output was connected to RL electrode point on the simulator. The patch was connected to the front end device and was configured in continuous monitoring mode. The experimental setup used

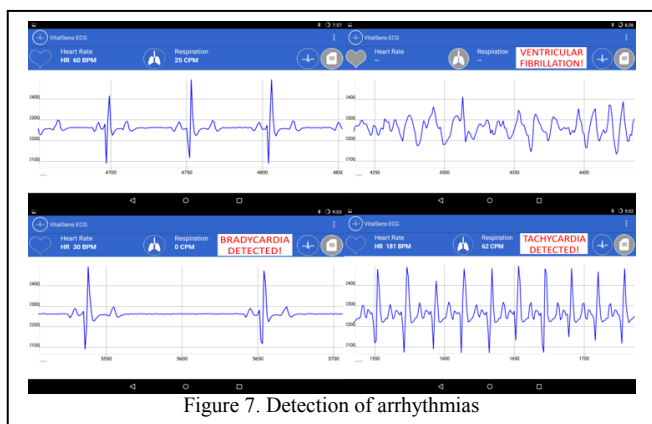

Figure 7. Detection of arrhythmias

for the test is shown in Fig. 6. Fig. 7. shows snapshots of alerts generated on the front end device by the patch, on detection of ventricular fibrillation, bradycardia and tachycardia, along with a normal ECG snapshot. Signals prone to motion artifacts were detected with appreciable accuracy and removed.

### IV. CONCLUSION

An ultra-low power ECG platform for continuous and minimally intrusive real-time monitoring and analysis is presented. The platform implements light weight algorithms ideal for systems with minimal processing capabilities. The paper presented a single lead model of the proposed platform. The effectiveness of the single lead system was verified in a controlled setting using a simulator. Next step involves carrying out a large scale clinical validation to understand the stability of the algorithms and the acceptability of the proposed model in a clinical setting. A clinical validation protocol would be prepared and an ethics committee approval would be obtained prior to the study.

### REFERENCES

- [1] K. A. Salam and G. Srilakshmi, "An algorithm for ECG analysis of arrhythmia detection," in *Electrical, Computer and Communication Technologies (ICECCT), 2015 IEEE International Conference on*, 2015, pp. 1–6.
- [2] T.-B. Nguyen, W. Lou, T. Caelli, S. Venkatesh, and D. Phung, "Individualized arrhythmia detection with ECG signals from wearable devices," in *Data Science and Advanced Analytics (DSAA), 2014 International Conference on*, 2014, pp. 570–576.
- [3] H. Sugano, S. Hara, T. Tsujioka, S. Nakajima, T. Inoue, K. Takeuchi, and H. Nakamura, "Continuous ECG data gathering by a wireless vital sensor—Evaluation of its sensing and transmission capabilities," in *Spread Spectrum Techniques and Applications (ISITA), 2010 IEEE 11th International Symposium on*, 2010, pp. 98–102.
- [4] E. S. Winokur, M. K. Delano, and C. G. Sodini, "A Wearable Cardiac Monitor for Long-Term Data Acquisition and Analysis," *IEEE Transactions on Biomedical Engineering*, vol. 60, no. 1, pp. 189–192, Jan. 2013.
- [5] D. G. Guo, F. E. Tay, L. M. Yu, L. Xu, M. N. Nyan, F. W. Chong, K. L. Yap, and B. Xu, "A wearable BSN-based ECG-recording system using micromachined electrode for continuous arrhythmia monitoring," in *Medical Devices and Biosensors, 2008. ISSS-MDBS 2008. 5th International Summer School and Symposium on*, 2008, pp. 41–44.
- [6] J. J. Oresko, Zhanpeng Jin, Jun Cheng, Shimeng Huang, Yuwen Sun, H. Duschl, and A. C. Cheng, "A Wearable Smartphone-Based Platform for Real-Time Cardiovascular Disease Detection Via Electrocardiogram Processing," *IEEE Transactions on Information Technology in Biomedicine*, vol. 14, no. 3, pp. 734–740, May 2010.
- [7] P. de Chazal, C. Heneghan, E. Sheridan, R. Reilly, P. Nolan, and M. O'Malley, "Automated processing of the single-lead electrocardiogram for the detection of obstructive sleep apnoea," *IEEE Transactions on Biomedical Engineering*, vol. 50, no. 6, pp. 686–696, Jun. 2003.
- [8] M. Guermandi, E. F. Scarselli, and R. Guerrieri, "A Driving Right Leg Circuit (DgRL) for Improved Common Mode Rejection in Bio-Potential Acquisition Systems," *IEEE Transactions on Biomedical Circuits and Systems*, pp. 1–1, 2015.
- [9] A. Nonclercq and P. Mathys, "Reduction of power line interference using active electrodes and a driven-right-leg circuit in electroencephalographic recording with a minimum number of electrodes," in *Engineering in Medicine and Biology Society, 2004. IEMBS'04. 26th Annual International Conference of the IEEE, 2004*, vol. 1, pp. 2247–2250.